

RE-TOOL YOUR MACHINE SHOP

Spring & Summer 2017



KING INDUSTRIAL

NEW

ALL-WEATHER HEAVY-DUTY SINGLE-TAP EXTENSION CORDS (40°C to 60°C) 12/3

Model	Length	AWG	Color	\$
K-2512-1T-YE	25'	12/3	YELLOW	20.99
K-2512-1T-RD	25'	12/3	RED	20.99
K-2512-1T-OR	25'	12/3	ORANGE	20.99

- 15A 125V, 1675W For indoor and outdoor use
- Ultra flexible / High visibility colors / Lighted ends

K-5012-1T-YE	50'	12/3	YELLOW	39.99
K-5012-1T-RD	50'	12/3	RED	39.99
K-5012-1T-OR	50'	12/3	ORANGE	39.99
K-5012-1T-GN	50'	12/3	GREEN	39.99

2' TRIPLE-TAP EXTENSION CORD

K-212-3T-RD	2'	12/3	RED	9.99
-------------	----	------	-----	------

ARCTIC FLEX

HYBRIDE POLYMER INDUSTRIAL AIR HOSES (40°C to 65°C) 300 PSI MAXIMUM PRESSURE HYBRID POLYMER INDUSTRIAL AIR HOSES

K-2514H	25'x1/4"	\$19.99
K-2538H	25'x3/8"	\$26.99
K-5014H	50'x1/4"	\$29.99
K-5038H	50'x3/8"	\$39.99
K-10014H	100'x1/4"	\$49.99
K-10038H	100'x3/8"	\$59.99

All-Weather Flexibility



2 cylinder cast iron single stage oil lubricated pump

STATIONARY 6.5 PEAK HP 60 GALLON AIR COMPRESSOR KC-6160V1

- 150 PSI max pressure
- 13.4 CFM @ 40 PSI
- 11.2 CFM @ 90 PSI
- High efficiency reed valves

\$799.



12" SLOW SPEED COLD CUT SAW

KC-315CS

- 4.5 HP motor
- Low 52 RPM blade speed is ideal for cutting ferrous metals
- Mitering head pivots to the right or left with positive stops at 45° and 90°



Optional 12" COLD CUT SAW BLADE

KM-1200 (Made in Italy)

\$299.

8" LOW SPEED BENCH GRINDER WITH LIGHT

KC-895LS

- Powerful 1/2 HP, 1,750 RPM motor
- Comes complete with diamond wheel dressing tool, tool rests, eye shields, coarse 60 grit and fine 120 grit 8" x 1" white aluminum oxide grinding wheels



\$129.99

5 PC. ACCESSORY BONUS PACKAGE FREE

INCLUDED WITH THE PURCHASE OF A PDM-30 MILLING DRILLING MACHINE **\$343.85**

MILLING DRILLING MACHINE with SAFETY GUARD & LIMIT SWITCH

PDM-30

- 16 1/2" swing
- 1 1/4" Drilling capacity
- 3" Face mill capacity
- 5" stroke
- Spindle taper R8
- 12 speeds

\$2199.

MILLING DRILLING MACHINE STAND

SS-45

Heavy-duty steel construction

\$249.99



11 amp. (220V)

7" X 12" METAL CUTTING BANDSAW

KC-712BC

- 11.5 amp. motor • Coolant system
- Adjustable ball bearing guides
- 4 speeds (85-130-180-235 FPM)

PATENTED TRU-LOCK quick locking vise system

\$1259.



H.S.S. & BI-METAL BLADES ("SKIP TOOTH")

Model	Length	Width	Blade Material	TPI	Thickness	Price
KBB-712-10	93"	3/4"	H.S.S.	10	.032"	\$19.99
KBB-712-14	93"	3/4"	H.S.S.	14	.032"	\$19.99
KBB-712-18	93"	3/4"	H.S.S.	18	.032"	\$19.99
KBB-712-BM-610	93"	3/4"	Bi-Metal	6-10	.032"	\$59.99
KBB-712-BM-1014	93"	3/4"	Bi-Metal	10-14	.032"	\$59.99



29 PC. TITANIUM DRILL BIT SET KDB-29T 29 (1/16"-1/2" x 1/64") **\$29.99**

DRILL PRESS CHUCK SAFETY GUARD KM-118 Fits KC-118FC **\$19.99**



17" DRILL PRESS with SAFETY GUARD & LIMIT SWITCH KC-118FC-(LS)

- 12.5 amp. motor
- 16 speeds (240-3400 RPM)
- 17" swing
- 3 1/4" stroke
- 5/8" chuck

\$699.

LONG STROKE

17" LONG STROKE DRILL PRESS with SAFETY GUARD KC-119FC-LS

- 12.5 amp. motor
- 12 speeds (255-2750 RPM)
- 34" swing
- 6" stroke
- 3/4" chuck

\$899.

17" DRILL PRESS KC-118FC

- 12.5 amp. motor
- 16 speeds 240-3400 RPM)
- 17" swing
- 3 1/4" stroke
- 5/8" chuck

\$599.



AIR COMPRESSORS & ACCESSORIES



NEW

10 GALLON 6.5 HP GAS WHEELBARROW AIR COMPRESSOR
KC-6510G1

- 150 PSI max pressure
- 14.1 SCFM @ 40 PSI
- 11.2 SCFM @ 100 PSI
- ASME safety valve
- High efficiency reed valves for maximum performance

\$799.99

PREMIUM HYBRID POLYMER GARDEN HOSES

Engineered Hybrid Polymer, combining PVC and rubber material for improved flexibility in extreme temperatures

K-5058GH
5/8" x 50 ft.
\$39.99

K-10058GH
5/8" x 100 ft.
\$69.99

150 PSI (Working) / 450 PSI (Burst)
Extreme All-Weather Flexibility Kink resistant



WET-DRY VACUUMS

Double filtration system

8530LP

- 12 ft. power cord
- Comes complete with 6 ft. x 1-1/4" hose, 2 pc. plastic extension wand, 30L dust bag, cartridge filter, foam filter, reusable filter, 10" floor sweep and crevice tool

\$79.99

Tank water drain



5 PEAK HP 5 30 LITERS GALLON US

8540LST

- 12 ft. power cord
- Comes complete with 6 ft. x 1-1/4" hose, 2 pc. extension wand, 40L dust bag, cartridge filter, foam filter, reusable filter, 10" floor sweep and crevice tool

\$149.99

Tank water drain



5 PEAK HP 10 40 LITERS GALLON US

8560LST

- 18 ft. power cord
- Comes complete with 8 ft. x 2-1/2" flex hose, 2 pc. 2-1/2" extension wand, contoured handle with air control, cartridge filter, foam filter, 14" floor sweep with squeegee insert, gulper tool, crevice tool and hanging accessory storage bag

\$239.99

Tank water drain



6.5 PEAK HP 16 60 LITERS GALLON US

HEPA CARTRIDGE FILTER
KVAC-1145

FITS: 8520LP, 8530LP, 8531LP-B, 8540LST, **\$29.99**

KVAC-1150
Fits: 8560LST **\$29.99**

2 cylinder cast iron single stage oil lubricated pump

5.5 PEAK HP 24 GALLON AIR COMPRESSOR
KC-3124V1

- 150 PSI max pressure
- 7.6 CFM @ 40 PSI
- 6.0 CFM @ 90 PSI

\$749.



COMPRESSOR OIL BOTTLE
KW-077
(850ml)

\$7.99

TIRE INFLATION GUN WITH PRESSURE GAUGE
K-1630

\$19.99



5.5 PEAK HP 20 GALLON AIR COMPRESSOR
KC-2051H1

- 150 PSI max pressure
- 7.6 SCFM @ 40 PSI
- 6.0 SCFM @ 90 PSI

2 cylinder cast iron single stage oil lubricated pump

\$699.



3 cylinder cast iron single stage oil lubricated pump

HIGH OUTPUT 6.5 PEAK HP 60 GALLON AIR COMPRESSOR
KC-5160V1

- 150 PSI max pressure
- 22.6 SCFM @ 40 PSI
- 18.5 SCFM @ 100 PSI
- High efficiency reed valves

\$1299.



2 cylinder cast iron single stage oil lubricated pump

HIGH OUTPUT 7.5 PEAK HP 80 GALLON AIR COMPRESSOR
KC-7180V1-MS

- High output 30 CFM @ 100 PSI
- 150 PSI max pressure
- 43 SCFM @ 40 PSI
- 30 SCFM @ 100 PSI
- Heavy-duty 1/2" ball valve and easy to read tank pressure gauge

\$2999.



Comes with magnetic starter

71 PC. AIR TOOL KIT

8171
Comes with 1/2" Impact, Wrench, 3/8" Ratchet Wrench, Air Hammer and 1/4" Die Grinder

\$119.99



SPRAY GUN KITS

8180 8182 8185
8190 HVLP

\$29.99 \$39.99 \$49.99 \$59.99

8190 HVLP

\$59.99

8195

\$79.99



HEPA CARTRIDGE FILTER
KVAC-1145

FITS: 8520LP, 8530LP, 8531LP-B, 8540LST, **\$29.99**

KVAC-1150
Fits: 8560LST **\$29.99**



METAL FORMING MACHINES

16 GAUGE BOX AND PAN BRAKE

KC-BP4816

- Bending length 48 1/2"
- Capacity 16 gauge
- Weight 330 lbs

\$999.



22 GAUGE BOX AND PAN BRAKE

BB-BP4822

- Bending length 48 1/4"
- Capacity 22 gauge
- Weight 253 lbs

\$899.



16 GAUGE HANDBRAKE

BB-H4816

- Bending length 48 1/2"
- Capacity 16 gauge
- Weight 385 lbs

\$799.



52" FOOT SHEAR

KC-F5216

- Cutting length 52"
- Capacity 16 gauge
- Weight 1080 lbs

\$2199.

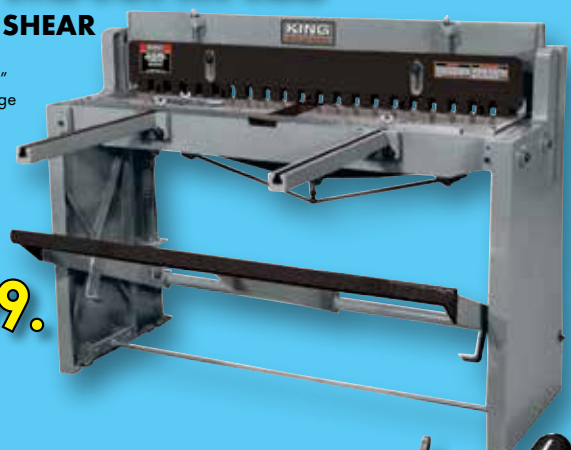

FLOOR MODEL BOX AND PAN BRAKE

KC-BP4812

- Bending length 48"
- Capacity 12 gauge
- Weight 1140 lbs

\$3399.

SLIP ROLLS

KC-S5016

- Max. length 50"
- Capacity 16 gauge
- Weight 50 lbs

\$1399.

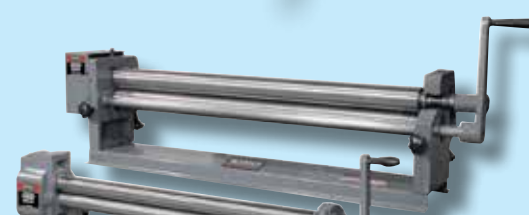

KC-S3622

- Max. length 36"
- Capacity 22 gauge
- Weight 176 lbs

\$599.



KC-S2422

- Max. length 24"
- Capacity 22 gauge
- Weight 81 lbs

\$499.



SHEAR, BRAKE AND ROLL

KC-1220

- Max. length 12"
- Maximum thickness 20 gauge
- Weight 95 lbs

\$419.

KC-3020

- Max. length 30"
- Maximum thickness 20 gauge
- Weight 300 lbs

\$799.

KC-4020

- Max. length 40"
- Maximum thickness 20 gauge
- Weight 387 lbs

\$1159.



3 IN 1 METAL FORMING MACHINES

ARBOR PRESS

KAP-3

- Precision cut steel rams and pinions for accurate operation
- Capacity: 3 Ton
- Diameter of work: 12 1/2"
- Capacity over table: 12"

\$389.99



COMBINATION ROTARY MACHINE

KC-RM22

- Cutting capacity (mild steel): 22 Gauge
- Distance between shaft centers: 2"
- Depth of throat to frame: 7"
- Includes 6 dies for hooking (2), burring, wiring, ogee beads and crimping

\$699.

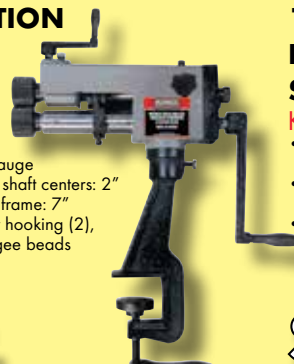

12" HAND SHEAR

KC-HS12

- Level arm with compensating spring
- Easy cutting across the entire length
- Rigid cutter body

\$199.99



4 TON HAND NOTCHER

KC-N616

- Heavy cast-iron construction
- 16 Gauge notching capacity (mild steel)
- 18 Gauge piercing capacity (mild steel)
- Maximum notch (6" X 6" x 90°)
- Weight 165 lbs

\$699.

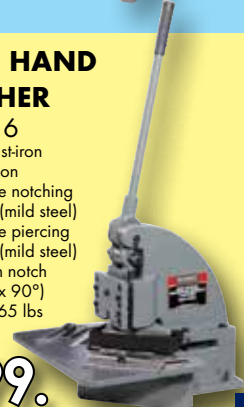

DUALSAW SAW KITS

CS300

- Cuts hard and soft metals, hardwood, PVC, Iron, plastics, aluminum, copper, stainless steel with ease and precision
- Kit includes set of universal tungsten carbide tipped (TCT) blades, 10 pcs. lubricating wax sticks, control handle, arbor tool and sturdy carrying case

Powerful 4.5 amp. motor
\$99.99



CS490

- Cuts hard and soft metals, hardwood, PVC, Iron, plastics, aluminum, copper, stainless steel with ease and precision
- Kit includes set of universal tungsten carbide tipped (TCT) blades, 10 pcs. lubricating wax sticks, control handle, arbor tool and sturdy carrying case

Powerful 8 amp. motor
\$129.99



POWER TOOLS & AUTOMOTIVE EQUIPMENT

3" X 79" METAL BELT SANDER

KC-379MS

- Sanding belt rotates on 7-1/2" vented drive wheel and solid rubber rear wheel for maximum tracking and sanding control
- Head pivots up or down on base for easy and safe work heights
- Horizontal working height of 36"
- Comes with 80 Grit pure zirconia sanding belt



2 HP (220V)

Hinged top cover for access to entire length of belt for larger pieces

3" x 79" PURE ZIRCONIA SANDING BELTS

Model	Belt Size	Grit	Unit	Price
SB-379-60	3"x79"	60	1	\$17.99
SB-379-80	3"x79"	80	1	\$17.99
SB-379-120	3"x79"	120	1	\$17.99

\$899.

12" HEAVY-DUTY BENCH GRINDER WITH FLOOR STAND

KC-1295

- Robust cast-iron wheel guards and dust vents with 2-1/2" T-fitting adaptor for dust collection



1.5 HP Direct Drive Motor (220V)

\$1199.

BENCH GRINDERS

BENCH GRINDER STAND

SS-150

- Made of cast iron with coolant reservoir
- 32 3/4" high



\$69.99

KC-690

- 3.5 amp. motor
- 3500 RPM

\$56.99



KC-890

- 7 amp. motor
- 3450 RPM

\$99.99



KC-1090

- 14 amp. motor
- 1720 RPM

\$299.99



VARIABLE SPEED HAND-HELD BLOWER/VACUUM

8317

- 116 CFM, max air speed 195 km/h (121 mph)
- Variable speed (6,000-14,000 RPM)

\$25.99



WET/DRY SHARPENER 4 1/2" X 1 1/2"

KC-4500S

- Forward/reverse switch allows the wheel to rotate in both directions
- 220 grit wheel runs at 170 RPM

\$69.99

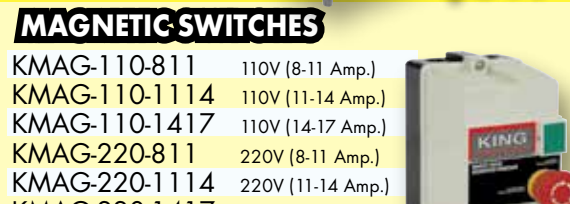

MAGNETIC SWITCHES

- KMAG-110-811 110V (8-11 Amp.)
- KMAG-110-1114 110V (11-14 Amp.)
- KMAG-110-1417 110V (14-17 Amp.)
- KMAG-220-811 220V (8-11 Amp.)
- KMAG-220-1114 220V (11-14 Amp.)
- KMAG-220-1417 220V (14-17 Amp.)
- KMAG-220-1721 220V (17-21 Amp.)

\$89.99 EOL



FIREPROOF 3" METAL DUST COLLECTION HOSES KIT

KM-102

- Kits Includes: 2 - 8ft. (2.5M) 130° Fireproof hoses
- 4 - Wire hose clamps (3")

\$69.99



3" WIRE HOSE CLAMP

K-1316

\$1.99 EA



DIGITAL FRACTIONAL CALIPER

KM-106

- Converts to inches (decimal and fractional) and metric readings
- Waterproof to IP54 standards
- Two 3V Lithium batteries included

\$29.99



2 HP METAL DUST COLLECTOR

KC-7300C

- Powerful 2 HP, 220V motor
- 2 Step activation safety switch with line voltage interruption in case of power failure
- Ideal for collection of metal chips and abrasive dust produced by metal sanders, grinders, cold cut saws, deburring and chamfering machines
- Large metal chips collection drawer is easy to access and clean
- 6" inlet with Y-inlet adaptor with two 3" dust inlets allowing up to connect up to two metalworking machines
- Comes with large paper filter and iron activated carbon filter



\$1299.

MILLING DRILLING MACHINES & ACCESSORIES

15" DRILL PRESSES with DUAL LASER GUIDE SYSTEM

KC-117N

- 7.5 amp. motor
- Spindle taper MT #2
- 16 speed (220-3600 spindle RPM)
- 3-1/8" stroke
- 5/8" chuck



\$399.



- KC-117FN
- 7.5 amp. motor
 - Spindle taper MT #2
 - 16 speed (220-3600 spindle RPM)
 - 3-1/8" stroke
 - 5/8" chuck

\$479.

DRILL PRESS
CHUCK
SAFETY
GUARD
KM-122
Fits KC-122FC
\$19.99

22" DRILL PRESS

- KC-122FC
- 12.5 amp. motor
 - 1 1/4" capacity
 - Spindle taper MT #4
 - 12 speeds (180-4200 RPM)
 - 4 3/4" stroke
 - 3/4" chuck

\$999.

22" DRILL PRESS with SAFETY GUARD & LIMIT SWITCH

- KC-122FC-(LS)
- 12.5 amp. motor
 - 1 1/4" capacity
 - Spindle taper MT #4
 - 12 speeds (180-4200 RPM)
 - 4 3/4" stroke
 - 3/4" chuck

\$1099.

HEAD TILTS
90° TO THE
LEFT AND
30° TO THE
RIGHT

21" GEARHEAD DRILLING MACHINE WITH SAFETY GUARD & LIMIT SWITCH

- KC-40HS (220V)
KC-40HS-6 (600V)
- 1.5 HP Motor
 - Forward & Reversing Switch
 - 1 1/4" Drilling Capacity
 - 20 7/16" Swing
 - Spindle Taper MT#3
 - 6 Speeds (60-1500 RPM)
 - Face Mill Capacity 4"
 - End Mill capacity 3/4"

\$3999.

FREE
ANGLE
VISE



20 PC. TITANIUM COATED
END MILL SET
KM-120
TITANIUM
NITRIDE
COATED HIGH
SPEED STEEL
2 & 4 Flute (10pcs. each)
Imperial, Single End

\$159.99

DRILL
PRESS VISE

- 3" - KPV-3 **\$15.99**
- 4" - KPV-4 **\$19.99**
- 5" - KPV-5 **\$29.99**
- 6" - KPV-6 **\$39.99**

52 PC. CLAMPING
KITS

- KCL-5212 **\$79.99**
Fits 1/2" table slots
- KCL-52 **\$79.99**
Fits 5/8" table slots

CROSS SLIDE VISES
• Extremely versatile
• Makes lateral or
longitudinal
adjustments simple

- 4" - KCV-4N **\$59.99**
- 5" - KCV-5N **\$79.99**
- 6" - KCV-6N **\$99.99**

KEYLESS DRILL CHUCKS

- KDC-12X **\$69.99**
1/2"JT#33
- KDC-58X **\$79.99**
5/8"JT#3
- KDC-34X **\$119.99**
3/4"JT#4

COMPOUND SLIDE TABLES

- KCT-512 **\$179.99**
5 1/2" X 12"
1/2" T-slots
- KCT-618 **\$199.99**
6" X 18 1/2"
1/2" T-slots

RADIAL DRILLING MACHINE WITH SAFETY GUARD KC-35/SS-35

- 1.5 HP Motor
- 21 1/4" Max. distance spindle nose to table
- 38 1/2" swing
- MT #3 Spindle taper
- Speeds 5(340-3000 R.P.M.)
- 5 1/4" Spindle stroke
- 4 1/2" Column diameter
- 21 5/8" x 19 5/8" Table dimensions
- 14" Head travel
- 5/8" Size of T-Slot on table
- Complete with forward reverse switch, 1/2" chuck

HEAD TILTS
90° TO THE
LEFT AND
30° TO THE
RIGHT

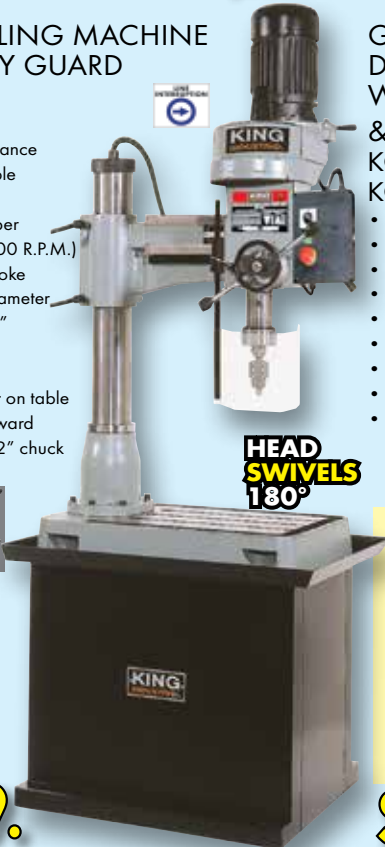

\$3499.

GEARHEAD MILLING DRILLING MACHINE WITH SAFETY GUARD & LIMIT SWITCH

- KC-40HC (220V)
KC-40HC-5 (600V)
- 1.5 HP Motor
 - Forward & Reversing Switch
 - 1 1/4" Drilling Capacity
 - 20 7/16" Swing
 - Spindle Taper R-8
 - 6 Speeds (60-1500 RPM)
 - Face Mill Capacity 4"
 - End Mill capacity 3/4"
 - Working surface of table 23" x 7 1/2"

FREE
ANGLE
VISE

Free Bonus Package **\$343.00**

5 PC ACCESSORY BONUS PACKAGE FREE INCLUDED WITH THE PURCHASE OF A KC-45 MILLING DRILLING MACHINE
Includes: angle drill press vise, drill chuck with key, drill chuck arbor, carbide tipped face mill and face mill arbor



\$4599.

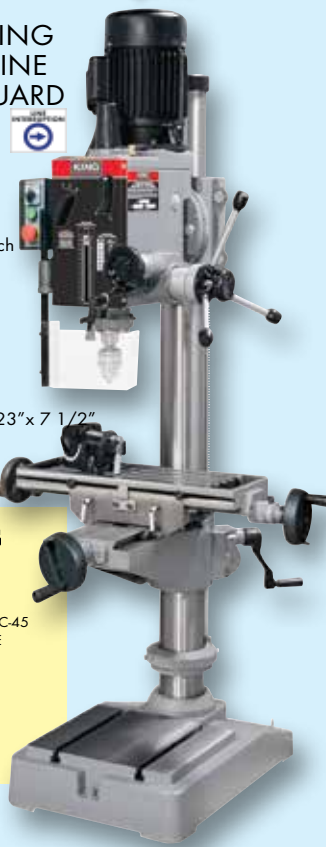

POWER
DOWNFEED
& TAPPING

RECIRCULATING
COOLANT
SYSTEM

23" GEARHEAD DRILLING MACHINE WITH SAFETY GUARD & LIMIT SWITCH

- KC-50
- 2 HP motor
 - 27 1/2" swing
 - 7" stroke
 - Speeds (60-870 / 120-1740)
 - 1 1/2" capacity
 - Spindle taper MT#4
 - 5/8" Chuck & key included

\$4799.



18 PC. COLLET SETS

Includes straight shank, 15 collets, wrench and plastic case.

KCS-4015

- Straight shank taper ISO 40
- Draw Bar 5/8" WII

KCS-R8-15

- Straight shank taper R8
- Draw Bar 7/16" NF 20



\$349.99 ea.

K-TYPE SWIVEL BASE MILLING VISES



3"- 4"- 6"- 8"-
 KMV-3M KMV-4M KMV-6M KMV-8M
\$99. \$159. \$199. \$299.

HORIZONTAL & VERTICAL ROTARY TABLES

KC-HVRT-6

Size 6"

\$379.

KC-HVRT-8

Size 8"

\$559.



TAILSTOCK FOR ROTARY TABLE

KC-TRT-6

Fits: KC-HVRT-6, KC-HVRT-8

\$129.99



DIVIDING PLATES FOR ROTARY TABLE

KC-DPRT-6

Size 6"

\$129.99 ea.

KC-DPRT-8

Size 8"



SPECIAL PACKAGE PROMOTION

942VS-DELUXE Installed with

- 942VS-6-NF
- MILLING MACHINE
- PFM-9422
- TABLE POWERFEED
- 20i-M-1230
- FAGOR DIGITAL READOUT SYSTEM
- KCS-R8-15
- 18 PC. COLLET SET
- KMV-6N
- 6" K-TYPE SWIVEL BASE MILLING VISE

\$12699.

OPTIONAL

PFM-9422 TABLE POWERFEED LONGITUDINAL

1 amp motor, 440 lbs TORQUE

\$649.



VERTICAL TURRET MILLING MACHINES

GEARHEAD MILLING DRILLING MACHINE WITH SAFETY GUARD & LIMIT SWITCH

KC-45

- 1.5 HP Motor
- Forward & Reversing Switch
- 20 7/16" Swing
- 5" Stroke
- 6 speeds (60-1500 RPM)
- 9 1/2" X 32 1/4" Table
- 1 1/4" Drill capacity
- 4" Face mill capacity
- Spindle taper R8

OPTIONAL

TABLE POWERFEED ATTACHMENT

PFM-31

For # KC-45

\$569.

OPTIONAL

MILLING DRILLING MACHINE STAND

SS-45

Heavy-duty steel construction

FAGOR DIGITAL READOUT SYSTEMS

20i-M-1230

(Fits 942VS-6-NF) 2 AXIS with 12" x 30" scales

\$1799.

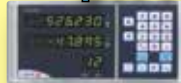

20i-M-1836

(Fits 1050VS) 2 AXIS with 18" x 36" scales

\$1799.

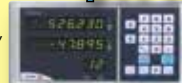

30i-M-183616

(Fits 1050VS) 3 AXIS with 18" x 36" x 16" scales

\$2499.



MILLING DRILLING MACHINE WITH DIGITAL READOUT, SAFETY GUARD & LIMIT SWITCH

KC-20VS-2

- 1 HP Motor
- 13" Max. distance spindle nose to table
- 13" swing • R8 Spindle taper
- 2" Spindle stroke
- Speeds 2(50-1125 / 100-2250 RPM)
- 7 1/16" x 27 1/2" Table dimensions
- 1/2" Size of T-Slot on table

- Comes with 1/2" chuck, chuck key, R8 chuck arbor, safety guard, 2 T-bolts, oil bottle, adjustment wrenches, hex. keys and tool box



OPTIONAL

MILLING DRILLING MACHINE STAND

SS-20VS

Heavy-duty steel construction

\$249.99

\$1899.

VARIABLE SPEED DRIVE

VERTICAL TURRET MILLING MACHINE 942VS-6-NF

- 3 HP Motor
- R-8 Spindle taper

- Size of table 9" x 42"
- Table travel 30"
- Saddle travel 12"
- Knee travel 16"
- Quill travel 5"

- 2 speed variable speed drive (70-500, 600-4200 R.P.M.)
- Max. distance spindle to table 19"
- Distance spindle to column 6 3/4"-19"
- Quill power feed (.0015", .003", .006")
- Ram movement 12"

\$10999.

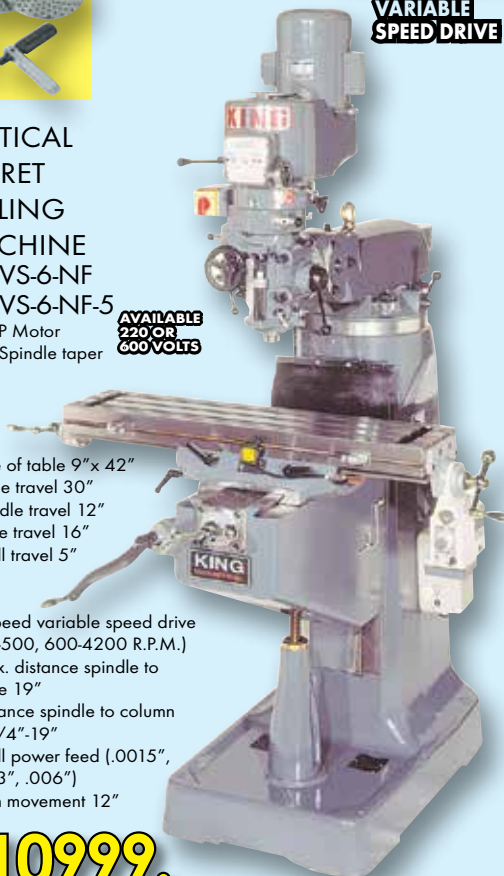

VERTICAL TURRET MILLING MACHINE 1050VS

- 5 HP Motor
- ISO-40 Spindle taper
- Size of table 10" x 50"
- Table travel 36"
- Saddle travel 16 1/2"
- Knee travel 16"
- Quill travel 5"

- 2 speed variable speed drive (70-500, 600-4200 RPM)
- Max. distance spindle to table 18"
- Distance spindle to column 24"
- Quill power feed (.0015", .003", .006")
- Ram movement 24"

\$13499.

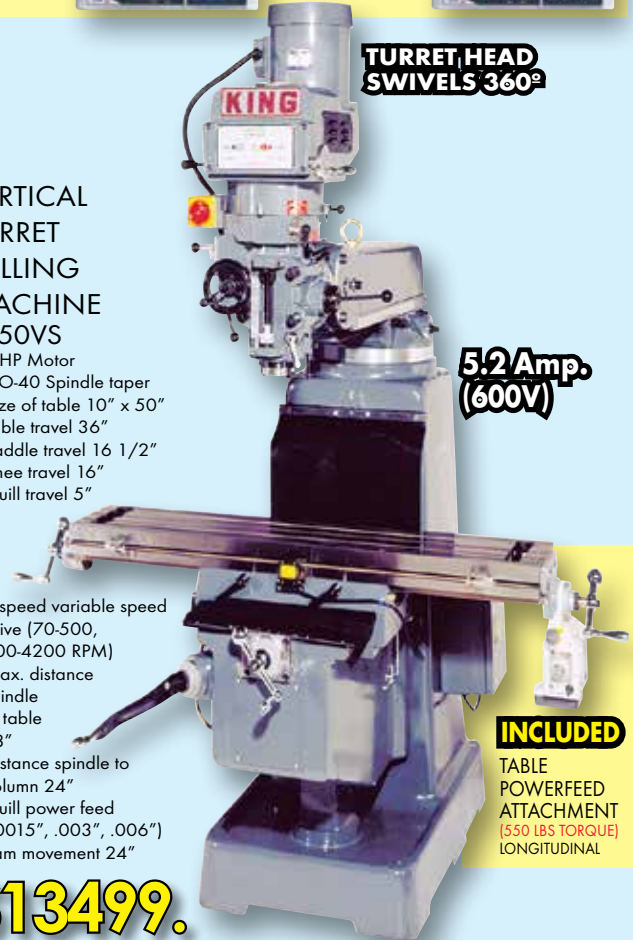

TURRET HEAD SWIVELS 360°

5.2 Amp (600V)

INCLUDED

TABLE POWERFEED ATTACHMENT (550 LBS TORQUE) LONGITUDINAL

METAL LATHES & ACCESSORIES

7" X 12" VARIABLE SPEED MINI METAL LATHE

KC-0712ML

- 3/4" spindle bore
- Variable speeds 2 (0-1100, 0-2500 RPM)
- Comes complete with quick change gear box, face plate, steady rest, replacement gears, 4-way tool post, MT#2 dead center, threading dial indicator, 4"-3 jaw chuck, emergency stop button, chuck key and hex. keys

\$999.99



5.5 Amp
(110V)

10" X 22" BELT DRIVE METAL LATHE

KC-1022ML

- 1" spindle bore
- Spindle speeds 6 (150-2400) RPM
- Comes complete with 5"-3 jaw chuck, 6-1/2"-4 jaw chuck, replacement gears, 4 way tool post, steady rest, follow rest, 8" face plate, thread chasing dial indicator, MT#3 dead center, full length splash guard, tool box, chuck key and hex. keys

\$2399.

12 Amp
(110V)

OPTIONAL
METAL LATHE
STAND
SS-1022
Heavy-duty
steel construction

\$249.99



12" X 36" GEARHEAD METAL LATHE

- 1 1/2" spindle bore
- Spindle speeds 9 (60-1500) RPM
- 40(4-112 T.P.I.) 30(.2 - 4.5mm) thread cutting
- Comes complete with 6"-3 jaw chuck, 8"-4 jaw chuck, imperial and metric gears, quick change tool post, steady rest, follow rest, 10" DI-4 camlock face plate, thread chasing dial indicator, MT#3 dead center, MT#3 arbor taper, 1/2" drill chuck, full length splash guard, tool box, chuck keys and hex. keys

1.5 HP
(220V)



KC-1236ML/SS-1236 KC-1236ML/KM-053/SS-1236

\$4399.

\$4999.

WITH TAPER ATTACHMENT

BONUS
GEARHEAD METAL LATHE
STAND INCLUDED

14" X 40" GEARHEAD METAL LATHE

- Spindle speeds 8(70-2000 RPM)
- 1 7/16" spindle bore
- 34(4-56 T.P.I.) 26(.4 - 7mm) thread cutting
- Comes complete with 6"-3 jaw chuck, 8"-4 jaw chuck, replacement gears, quick change tool post, steady rest, follow rest, 12" DI-4 camlock face plate, coolant system, full length splash guard, thread chasing dial indicator, 2 MT#3 dead centers, JT#5-MT#3 sleeve, chip tray, tool box, halogen lamp, chuck keys, hex. keys, and cabinet stand with foot brake

2 HP
(240V)



KC-1440ML-6 KC-1440ML-6/KM-054

\$6299.

\$6899.

WITH TAPER ATTACHMENT

**CABINET STAND WITH
FOOT BRAKE INCLUDED**

16" X 40" HIGH PRECISION "TOOL ROOM" METAL LATHE

- Spindle speeds 16(45-1800 RPM)
- 2" spindle bore diameter
- 45(2-72 T.P.I.) thread cutting
- Comes complete with 8"-3 jaw chuck with inside & outside jaws, 12"-4 jaw chuck, quick change tool post and two 3/4" tool holders, steady and follow rests with roller guides, 14" (D1-6) camlock face plate, MT #4 standard dead centre, MT #4 carbide tipped dead centre, MT #4 to MT #6 spindle sleeve adapter, halogen light, coolant system, full length splash guard, manual micrometer carriage stop, tool box and wrenches

4 HP
(600V)

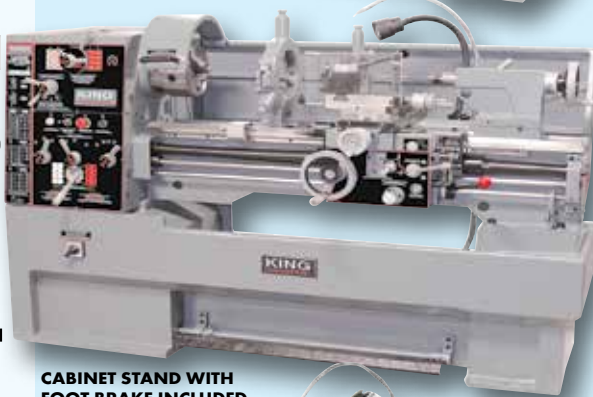

KC-1640ML KC-1640ML/KM-055

\$11999.

\$12499.

WITH TAPER ATTACHMENT

**CABINET STAND WITH
FOOT BRAKE INCLUDED**

16" X 60" GEARHEAD ENGINE LATHE

KC-1660GH

- Spindle speeds 16(33-2000 RPM)
- 2 1/16" Spindle bore diameter
- 4-56 T.P.I. thread cutting
- Comes complete with 8"-3 jaw chuck with inside & outside jaws, 10"-4 jaw chuck, quick adjust 6-way tool post, steady rest, follow rest, 14" (D1-6) camlock face plate, taper attachment, 1 live center MT #4, 2 dead centers MT#4 & MT #6, thread chasing dial, metric and imperial dials, halogen light, coolant system, full length splash guard, 4 positions cross slide stop, cabinet stand (full length with foot brake incorporated) and a tool box

7.5 HP
(600V)



\$17999.

**CABINET STAND WITH
FOOT BRAKE INCLUDED**

7 PC. CARBIDE CUTTER HOLDER SETS

- 1/4" Carbide Steel 2 position Cutter Tips (5pcs.)
- Carbide Steel Inserts (2pcs.)

INCLUDED
Screwdriver and
3 adjustment keys



KM-047
3/8" Shank
\$189.

KM-057
5/8" Shank
\$199.

Fits Models:
KC-0712ML, KC-1022ML

Fits Models:
KC-1236ML, 14440ML-6
KC-1640GH, KC-1640ML
KC-1660GH

LIVE CENTERS

Fitted with taper roller bearings



**Very
Accurate**

KLC-2M
TAPER SHANK - MT#2

\$59.

KLC-3M
TAPER SHANK - MT#3

\$79.

TAPER ATTACHMENT



**Taper Attachment must be
ordered together with Lathe**

These Taper Attachments are designed
to fit our 12" x 36", 14" x 40" & 16" x 40"
Metal Lathes models

KC-1236ML, KC-1440ML-6 & KC-1640ML

7 PC. QUICK CHANGE TOOL POST KITS



KQCT-0012
Fits most lathes up
to 0 to 12" swing

\$249.99

KQCT-1015
Fits most lathes
between 10" to 15" swing

\$299.99

KQCT-1318
Fits most lathes
between 13" to 18" swing

\$399.99

FAGOR DIGITAL READOUT SYSTEM



20i-T-1040
(Fits KC-1640ML)

20i-T-1260
(Fits KC-1660GH)

**2 AXIS with
12" x 40" scales
\$2199.**

**2 AXIS with
12" x 60" scales
\$2599.**

METAL CUTTING BANDSAWS

5" x 6" METAL CUTTING BANDSAW KC-129C

- 3 speeds (80-120-200 FPM)
- Comes with wheels for portability

8 Amp. (110V)

\$439.99



H.S.S. & BI-METAL BLADES						
Model	Length	Width	Blade Material	TPI	Thickness	Price
KBB-115-10	64 1/2"	1/2"	H.S.S.	10	.025"	\$13.99
KBB-115-14	64 1/2"	1/2"	H.S.S.	14	.025"	\$13.99
KBB-115-18	64 1/2"	1/2"	H.S.S.	18	.025"	\$13.99
KBB-115-24	64 1/2"	1/2"	H.S.S.	24	.025"	\$13.99
KBB-115-BM-10	64 1/2"	1/2"	Bi-Metal	10	.025"	\$33.99
KBB-115-BM-14	64 1/2"	1/2"	Bi-Metal	14	.025"	\$33.99
KBB-115-BM-18	64 1/2"	1/2"	Bi-Metal	18	.025"	\$33.99

5" x 6" DUAL SWIVEL METAL CUTTING BANDSAW KC-129DS

- Head swivels 0° - 45° to the right and 0° - 60° to the left
- Adjustable hydraulic downfeed control
- Automatic shut-off switch
- Adjustable ball bearing guides
- Portable design for easy movement

ADJUSTABLE HYDRAULIC CYLINDER



8 Amp. (110V)

\$769.99



10" x 18" METAL CUTTING BANDSAW KC-227-2 (220V) KC-227-6 (600V)

- 4 speeds (114, 196, 288, 377 FPM)
- Carbide ball bearing blade guide
- Centralized control panel and automatic shut-off
- Adjustable hydraulic downfeed control
- To ensure reliable accurate cuts, both adjustable control arms can be positioned as close to the cut as possible
- Coolant system with regulator valves provide an even flow of coolant to the blade

H.S.S. BLADES					
Model	Length	Width	TPI	Thickness	Price
KBB-225-10	122"	1"	10	.032"	\$29.99
KBB-225-14	122"	1"	14	.032"	\$29.99

\$3999.



PATENTED TRU-LOCK quick locking vise system. Fully adjustable jaws for 0° to 45° angled cuts

Exclusive 24 volt control panel

**11.5 Amp. @220V
2.6 Amp. @600V**



10" x 18" VARIABLE SPEED SWIVEL METAL CUTTING BANDSAW KC-228S-V-2 (220V) KC-228S-V-6 (600V)

- Variable Speeds (73-312 FPM)
- Carbide ball bearing blade guides
- Adjustable hydraulic downfeed control
- Swivel base from 0° to 45°
- Coolant system with regulator valves provide an even flow of coolant to the blade

H.S.S. BLADES					
Model	Length	Width	TPI	Thickness	Price
KBB-225-BM-610	122"	1"	6-10	.032"	\$89.99
KBB-225-BM-812	122"	1"	8-12	.032"	\$89.99

\$5799.

**11.5 Amp. @220V
2.6 Amp. @600V**

PATENTED TRU-LOCK quick locking vise system. Fully adjustable jaws for 0° to 45° angled cuts

Exclusive 24 volt control panel



METAL CUTTING BANDSAWS

7" x 12" METAL CUTTING BANDSAW WITH GEAR DRIVE KC-712GH-5

- Returning coolant system
- 3 (110-230-340 FPM)
- Automatic shut-off
- Adjustable ball bearing guides

PATENTED GEAR DRIVE SYSTEM... is the ONLY one in the Canadian market which allows the user to change speeds without stopping the machine.



PATENTED TRU-LOCK quick locking vise system

14 Amp (110V)

\$1799.

7" x 12" DUAL SWIVEL METAL CUTTING BANDSAW KC-712DS

- Returning coolant system
- 4 speeds (98-164-246-328 FPM)
- Automatic shut-off
- Adjustable ball bearing guides

6 Amp (220V)



PATENTED TRU-LOCK quick locking vise system

\$2499.

9" x 18" METAL CUTTING SWIVEL BANDSAW KC-918S-V

- Speeds (80-250 FPM)
- Carbide ball bearing blade guides with rollers
- Centralized control panel and automatic shut-off
- Adjustable hydraulic downfeed control
- Precision blade tension adjustment
- Head swivels 0° to 45° in one direction
- Quick-positioning vise with fully adjustable jaws for 0° to 45° angles

Coolant system Included

VARIABLE SPEED

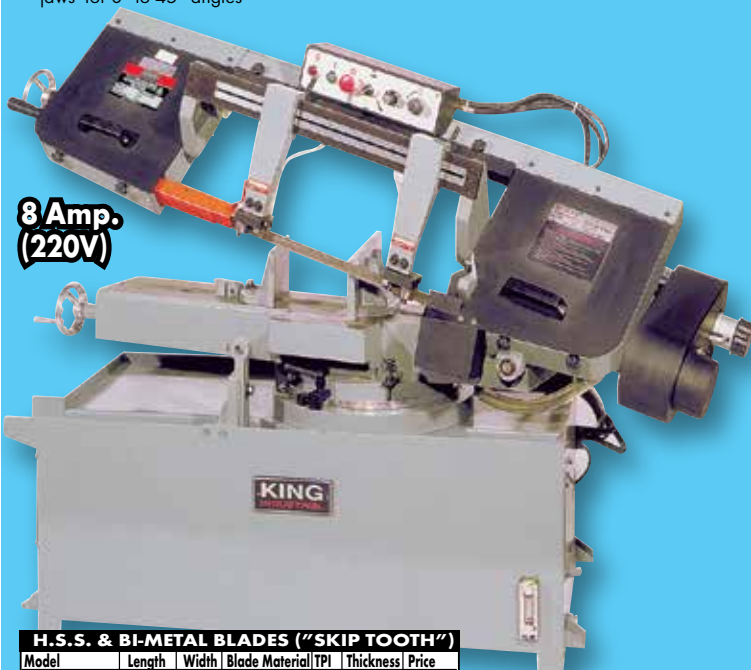

8 Amp (220V)

\$5799.

17" VARIABLE SPEED METAL/WOOD CUTTING BANDSAW KC-1700WM-VS

- Variable speeds (wood): 540-3600 SFPM
- Variable speeds (metal): 100-650 SFPM
- Voltage (input power): 220V, 1 phase, 60 Hz
- Comes with a 1/2" x 6 TPI wood cutting blade, 1/2" x 10 TPI metal cutting blade, laser guide, work lamp, miter gauge and a precision "TRU-RIP" aluminum rip fence with resaw guide



Blade speed digital readout

RESAW FENCE SYSTEM

23 1/2" x 17" cast iron table
Tilts 5° to the left & 45° to the right

2- 4" Dust chutes for dust collector hook-up

2 HP (8 Amp @ 220V)

\$3599.

18" METAL CUTTING BANDSAW KC-450

- Variable speed
- Handwheel controls speed
- Speed changes while the machine is in operation
- Comes complete with 4-way tilting table, and work light



7.5 Amp (220V)

\$4899.

H.S.S. & BI-METAL BLADES ("SKIP TOOTH")						
Model	Length	Width	Blade Material	TPI	Thickness	Price
KBB-918-10	131 3/4"	1"	H.S.S.	10	.032"	\$29.99
KBB-918-14	131 3/4"	1"	H.S.S.	14	.032"	\$29.99
KBB-918-BM-610	131 3/4"	1"	Bi-Metal	6-10	.032"	\$89.99
KBB-918-BM-812	131 3/4"	1"	Bi-Metal	8-12	.032"	\$89.99

INSPECTION CAMERAS

PALLET TRUCKS

INSPECTION CAMERA WITH LCD MONITOR

KC-9050

Kit includes:

- Camera handle, 9mm dia. x 39" flexible-obedient camera probe
- 2.4" diagonal TFT-LCD color monitor
- 3 accessory tools (45° mirror, magnetic pick-up, pick-up hook) and 4 AA batteries

\$99.99



4.5MM CAMERA PROBE FOR INSPECTION CAMERAS

KW-9123

- 4.5mm diameter x 39" flexible-obedient camera probe waterproof to IP67 standards
- LED lights inside the camera probe tip illuminate dark spaces

\$69.99



Ideal for inspection of very small hard-to-reach or hard-to-see areas

WIRELESS INSPECTION CAMERA WITH RECORDABLE LCD MONITOR

KC-9200

DIGITAL ZOOM 3X

- Kit includes: 39" x 9mm flexible-obedient camera probe, 39" x 10mm camera probe extension, 3.5" TFT-LCD wireless color monitor, monitor Li-ion charger, 3 accessory tools (45° mirror, magnetic pick-up, pick-up hook), USB and Video cables, 4GB SD memory card and 4 AA batteries

\$199.99



KC-2145N-NYL

(21" X 45")
Nylon wheels

\$399.99

3 position control handle

KC-2748N-NYL

(27" X 48")
Nylon wheels

\$399.99

KC-2748N-P

(27" X 48")
Poly wheels

\$399.99

QUICK-RELEASE FOOT PEDAL



Max. raised height of forks 7 1/2"

Min. height of forks 2.95"

QUICK-RELEASE FOOT PEDAL

QUICK-RELEASE FOOT PEDAL

5500 LBS CAPACITY

GASOLINE WATER PUMPS

KCG-2PGN-7

2"
NPT inlet and outlet

- 92' Total head lift (total height at sea level, to which water can be raised above original water level)
- Oil sensor shuts off engine when oil level is low
- Comes with 3 wire clamps, 4 hose adaptors, 4 rubber gaskets, strainer basket and strainer basket adaptor



Easy start recoil starter

6.5 HP
4 stroke air cooled OHV engine

\$299.99

KCG-3PG-7

3"
NPT inlet and outlet



Easy start recoil starter

6.5 HP
4 stroke air cooled OHV engine

\$319.99

GASOLINE ENGINES

KCG-65

- Powerful 6.5 HP, 4 stroke air cooled OHV engines
- Ideal for compressors, generators, pressure washers, go-karts and log splitters
- Counterclockwise drive shaft direction

\$179.99



KCG-130

- Powerful 13 HP, 4 stroke air cooled OHV engines
- Ideal for compressors, generators, pressure washers, go-karts and log splitters
- Counterclockwise drive shaft direction

\$349.99



WATER PUMP HOSE KITS

Each hose kit comes with a type A threaded camlock adaptor

CLEAR PVC REINFORCED SUCTION HOSES

FLAT PVC DISCHARGE HOSES

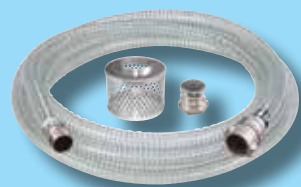

\$79.99

KW-252
2" X 25 ft

\$149.99

KW-253
3" X 25 ft



\$59.99

KW-502
2" X 50 ft

\$99.99

KW-503
3" X 50 ft

14" CUT-OFF SAW

8342N

- Large trigger switch in handle for safe and easy use
- Standard 14" abrasive wheel for cutting ferrous metal
- Quick release vise for holding workpiece, which allows cuts up to a 45° angle

INFRARED DIGITAL THERMOMETER WITH LASER POINTER

K-550

Temperature range (-50°C ~ 550°C) (-58°F ~ 1022°F)

\$39.99



(15 Amp. Motor)

\$149.99

2000W GASOLINE DIGITAL INVERTER GENERATOR

KCG-2001i

- Sine wave digital inverter generator provides stable current to power voltage-sensitive electronics
- Powerful 3 HP, 4 stroke air cooled OHV engine DC output for charging smartphones, tablets or any USB powered equipment
- DC Cigarette Lighter Socket: 12V/8 amp DC output
- AC Duplex Outlet: 120V/13.3 amp AC output



\$679.99

Optional

K-X2P \$119.99
Parallel Cable Kit
for connectivity between two inverters



GENERATOR EXTENSION CORDS

Converts a Nema L14-30P 240V 30 Amp Twist Lock plug into Nema 5-15/20R 120V 20A receptacles

K-L1430-10

Extension cord length: 10 feet
Gauge (AWG)/Cord: 12 (SJTW 4/C)

Number of 120V plugs: 4



\$29.99

K-L1430R-25

Extension cord length: 25 feet
Gauge (AWG)/Cord: 10 (SJTW 4/C)

Number of 120V plugs: 4



\$69.99

Resets

K-L1430-25-4T

Extension cord length: 25 feet
Gauge (AWG)/Cord: 10 (SJTW 4/C)

Number of 120V plugs: 4



\$69.99

Lighted End

ALL SEASON GENERATOR COVERS

Made of heavy-duty tarpaulin with PVC vinyl coating

K-42CVR

Fits Generators:
KCG-3500G, KCG-4200G

\$39.99



K-85CVR

Fits Generators:
KCG-5625G, KCG-6501G, KCG-7500G,
KCG-7501GE, KCG-8500GE

\$39.99



K-100CVR

Fits Generators:
KCG-9000GE, KCG-10000GE

\$39.99



RV GENERATOR ADAPTER

K-TT30R

This adapter allows a generator with a NEMA L5-30R 125V twist lock receptacle to be connected to recreational vehicles that use typical RV extension cords

\$12.99



PORTABLE & GASOLINE GENERATORS

950W PORTABLE GENERATOR

KCG-951G

- Powerful 2 HP, 2 stroke air cooled motor
- Brushless alternator and electronic ignition
- Outlet: 120V/6.7 amp AC output
- Outlet: 12V/5.3 amp DC output
- Easy start manual recoil starter
- AC and DC circuit breakers and reset buttons for safe operation
- Comes with DC cables and spark plug socket



\$179.99

1500W GASOLINE GENERATOR

KCG-1501GN

- Powerful 3 HP, 4 stroke air cooled motor
- Electronic ignition
- Low oil shut-off with indicator light protects the engine
- Duplex Outlet: 120V/10 amp. AC output
- Terminals: 12V, 8 amp. DC output
- Easy start recoil starter
- AC and DC circuit breakers for safe operation
- Comes with DC cables and spark plug socket



\$299.99

4200W GASOLINE GENERATOR WITH WHEEL KIT

KCG-4200G

- Powerful 7 HP, 4 stroke air cooled motor
- AVR system and electronic ignition
- Low oil shut-off with indicator light protects the engine
- Duplex outlet: 120V/20 Amp AC
- Twist lock outlet: 120V/240V/30 Amp AC
- Easy start recoil starter
- Voltage switch and ground terminal
- AC double throw circuit breaker and resets for safe operation
- Wheel kit includes 8" wheels and pivot handle



\$429.99

6500W GASOLINE GENERATOR WITH WHEEL KIT

KCG-6501G

- Powerful 15 HP, 4 stroke air cooled motor
- AVR system and electronic ignition
- Low oil shut-off with indicator light protects the engine
- Duplex outlet: 120V/20 Amp AC
- Twist lock outlet: 120V/240V/30 Amp AC
- AC double throw circuit breaker and resets for safe operation



\$679.99

8500W GASOLINE GENERATOR WITH ELECTRIC START & WHEEL KIT

KCG-8500GE

- Powerful 15 HP, 4 stroke air cooled motor
- AVR system and electronic ignition
- Two duplex outlets: 120V/20 Amp AC
- Two twist lock outlets: 120V/30 Amp and 120V/240V/30 Amp AC



\$879.99

ELECTRIC START
BATTERY INCLUDED

10000W GASOLINE GENERATOR WITH ELECTRIC START & WHEEL KIT

KCG-10000GE

- Powerful 15 HP, 4 stroke air cooled motor
- AVR system and electronic ignition
- Low oil shut-off with indicator light protects the engine
- Two duplex outlets: 120V/20 Amp AC
- Two twist lock outlets: 120V/30 Amp and 120V/240V/30 Amp AC
- Keyed electric start and easy start recoil starter
- AC double throw circuit breaker



\$999.99

ELECTRIC START
BATTERY INCLUDED

LED DUAL-HEAD WORK LIGHTS

LED WORK LIGHTS Cordless

KC-1201LED

10W Work light emits 1200 lumens

\$29.99

KC-1202LED-C

10W Work light emits 1200 lumens

\$49.99

KC-2401LED

20W work light emits 2400 lumens

\$49.99

KC-3601LED

30W work light emits 3600 lumens

\$74.99

KC-2402LED-ST

Emits 4800 lumens

- Quick release latch
- For indoor and outdoor use in dry locations

\$129.99

KC-3602LED-ST

Emits 7200 lumens

- Quick release latch
- For indoor and outdoor use in dry locations

\$199.99

HYDRAULIC SHOP PRESSES WITH GRID GUARD

- Great for straightening, pressing, bending or stamping
- Used to install or remove gears, bushings or bearings
- Adjustable bed height with support rods
- Comes with 2 pressure plates

OPTIONAL

9 PC. PUNCH & DIE KIT

KM-045

\$99.

10 TON

KHP-10T-GG

\$269.99

20 TON

KHP-20T-GG

\$399.99

3000 PSI GASOLINE HIGH PRESSURE WASHER

KPW-3001FM

- 3000 PSI, 2.3 GPM maximum water flow
- Thermal relief valve on pump to protect against overheating
- 25' high pressure hose and inlet hose quick connect coupling
- Comes with 10" pneumatic wheels for portability and 4 quick connect nozzles (0°, 15°, 25°, 40° and detergent)

\$439.99

7HP

JUMP STARTER / PERSONAL POWER SUPPLY

PX-500

- Charge or power all electronic devices, USB 5V electronics, 12V accessories and 16V/19V laptops.
- This 13,600 mAh portable jump starter & power supply is able to jumpstart a V8 engine (5L) up to 15 times.

\$129.99



2 TON FOLDING SHOP CRANE

KFC-2TN

- 8 ton hydraulic ram features top-of-stroke and safety overload bypass system for maximum pump protection.
- Compact design with retractable boom and foldable legs. Fold-up legs with safety pins extend to 68 1/2"

\$299.99

OPTIONAL

3/4 TON ENGINE LOAD LEVELER

KLV-1500

- Used for engine installation and removal
- Crank handle for tilting adjustments

\$49.99

PRESSURE ABRASIVE SANDBLASTERS

- Safety pressure relief valve
- Loading abrasive is made simple using the concave funnel top of the tank
- 1/2" (I.D.) x 8 ft abrasive feed hose
- Includes media gun, 4 interchangeable nozzles (2, 2.5, 3 & 3.5mm), water separator filter, protective blast hood and teflon tape

10 GALLON

KSB-10

\$199.99

20 GALLON

KSB-20

\$239.99

ADHESIVE WINDOW PROTECTORS

KM-097

Fits: KSB-110N-9

\$19.99

KM-098

Fits: KSB-350

\$19.99

REPLACEMENT CERAMIC NOZZLES

KM-036

Fits: KSB-110N-9 & KSB-350

4 PC. KIT

\$19.99

RECIRCULATING PARTS WASHERS

CLEANING BRUSH FOR PARTS WASHERS
KM-059

\$19.99

5 GALLON

20 GALLON

40 GALLON

KPW-205

- 5 gallon capacity
- Safety lever has fusible link
- Durable pump included

\$69.99

KPW-220

- 20 gallon capacity
- Safety lever has fusible link
- Durable pump included

\$169.99

KPW-240

- 40 gallon capacity
- Safety lever has fusible link
- Durable pump included

\$199.99

SANDBLAST CABINETS

\$169.99

KSB-110N-9

- Filtered fluorescent light
- Aluminum gun with 3 ceramic replacement nozzles
- 2 rubber gauntlet gloves mounted in front

\$599.

KSB-350

- Filtered fluorescent light
- Aluminum gun with 3 ceramic replacement nozzles
- 2 rubber gauntlet gloves mounted in front